

Guidelines for flush  
medians

*RTS 4*

November 1991  
Reprinted July 2001

Land Transport Safety Authority  
PO Box 2840  
Wellington  
Telephone: 04 494 8600  
Facsimile: 04 494 8601

ISSN: 1170-5337  
ISBN: 0-477-05267-3

## Contents

Disclaimer	4
1. Introduction	5
2. Existing references	6
3. Regulations	7
4. Driving rules	8
5. Guidelines	9
5.1 Basic flush median layout	9
5.2 End treatments	10
5.3 Pedestrian provisions	11
5.4 Intersection treatments	12
5.5 Night-time visibility and lighting	16
5.6 Colours and materials	17
6. References	18
7. Acknowledgements	19

## Disclaimer

Transit New Zealand, its members, employees and agents undertake no duty of care in contract, tort, or otherwise, to users (whether direct or indirect) of this document and make no warranties or representations of any kind whatsoever in relation to any of its contents.

The document is only made available on the basis that all users of it, whether direct or indirect, must take appropriate legal or other expert advice in relation to their own circumstances and must rely solely on their own judgement and such legal or other expert advice.

Under no circumstances will Transit New Zealand, its members, employees and agents be liable in any way whatsoever, whether in contract, tort (including negligence), for breach of any statutory or regulatory duty (to the fullest extent permissible by law), or otherwise, to any user (whether direct or indirect) of this document for any loss or damage whatsoever arising directly or indirectly as a result of the use in any way of this document.

Each exclusion in the clauses of this disclaimer and each protection given by it is to be constructed as a separate exclusion applying and surviving even if for any reason any of the exclusions or protections are held inapplicable in any circumstances.

## Disclaimer

Under no circumstances will Ministry of Transport, land Transport Division, its employees and agents be liable in any way whatsoever, whether in contract, tort (including negligence), for breach of any statutory or regulatory duty (to the fullest extent permissible by law), or otherwise, to any user (whether direct or indirect) of this document for any loss or damage whatsoever arising directly or indirectly as a result of the use in any way of this document.

## 1. Introduction

Flush medians (also referred to as painted or hatched medians) have been used sparingly for many years on New Zealand roads, generally to use up carriageway width on very wide roads.

More recently flush medians have been used on arterial and occasionally sub-arterial roads where property access needs to be maintained but where there are seen to be safety benefits in removing turning vehicles from the through traffic streams.

There is overseas evidence that the use of flush medians results in accident savings (1) and they are frequently recommended in accident investigation studies where the problems mentioned above have been identified.

There is also New Zealand data on the accident-saving potential of solid median islands (2). These may well be more appropriate where property access can be restricted to left turns in and out, and provided that right turns at intersections can be adequately provided for the greater cost would be considered (3).

Flush medians are intended primarily for urban (50km/h) and semi-urban (70km/h) roads.

In summary flush medians can be appropriate when:

- (a) Right turning traffic is interfering with through traffic (accident or delay problems).
- (b) Pedestrians are having difficulty crossing a busy road (accidents, delays or complaints).
- (c) The carriageway is excessively wide.
- (d) Property access needs to be maintained and any of the above conditions exist.

## 2. Existing references

The basic layout of flush medians is shown in the National Roads Board “Guide to Urban Road Markings” 1984, Section 2.7, page 8 (4); and the National Roads Board “Manual of Traffic Signs and Markings” 1975, Section 3.2.07, page 12 (5).

Another reference is NAASRA part 9 “Arterial Road Traffic Management”, section 3.2.7, page 17 (6)

This Guideline expands upon the above documents.

### 3. Regulations

Refer to the Traffic Regulations 1976 (as amended). (7)

## 4. Driving rules

The Road Code (8) makes it clear to drivers that they may use a flush median before or after turning right.

A flush median may **NOT** be used to overtake any moving motor vehicle except one whose driver has indicated a left turn.

The Road Code makes it clear to pedestrians that they may use a flush median to pause on while crossing the road but they must exercise care because turning vehicles also use the median.

## 5. Guidelines

### 5.1 Basic Flush Median Layout

Width                    Minimum    1.0 m  
                                  Maximum    3.5 m

Sidelines                100 mm wide solid reflectorised white

Diagonal bars         600 mm wide solid reflectorised white, at 2 to 1 slope

Spacing	Median length	Recommended range for Bar Spacing
	Less than 100 m	6 – 12 m
	100 – 500 m	10 – 15 m
	More than 500 m	12 – 20 m

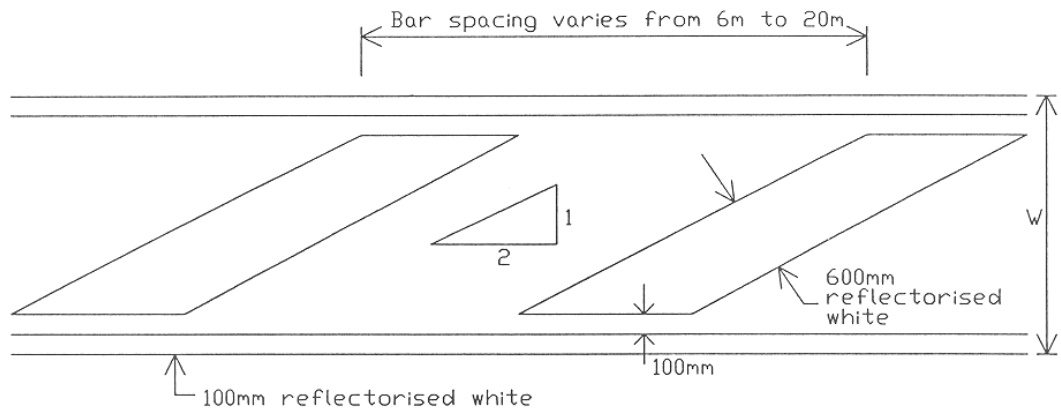

#### Notes

1. The minimum effective width of a flush median to remove turning traffic from through traffic lanes is 2.0 m. This will accommodate a 99 percentile car, (width 1.94 m) but not a truck (width 2.5 m, the legal maximum vehicle width).
2. Flush medians wider than 3.0 m can encourage overtaking, poor driving practices and even parking, and are not recommended.
3. The use of edge lines to protect parking, and a flush median can reduce vehicle speeds by better defining vehicle paths and narrowing the travelling lanes. For information on traffic lane width and parking refer to NAASRA Part 9 "Arterial Road Traffic Management" (6) and NAASRA Part 11 "Parking" (9).
4. Where there are large numbers of cyclists and/or left turning vehicles a lane width of less than 5.0 m may encourage use of the flush median for overtaking. This will increase the risk of collisions with pedestrians and other vehicles using the median, and is not recommended.
5. Effective bar spacing depends on the width and length of the median, and vehicle speeds, and should be chosen to take these factors into account.

## 5.2 End treatments

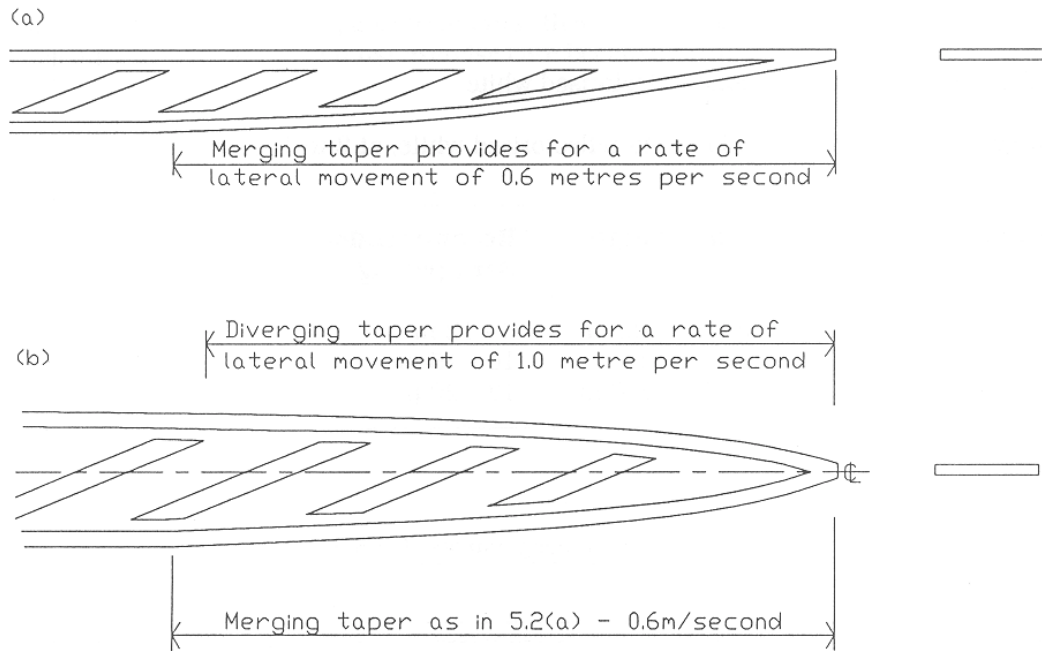

For further information refer to NAASRA Part 5 “Intersections at Grade” 1988 Section 5.9.2, Page 44 (10). Although they are applied specifically to the development and cessation of auxiliary through lanes, the principles in this section of the NAASRA Guide can also be applied to tapers at the start and termination of flush medians.

Merging tapers should provide for a maximum rate of lateral movement of 0.6 metres per second.

Diverging tapers should provide for a maximum rate of lateral movement of 1.0 metres per second.

These translate to:

Speed km/h	Merging taper (percent)	Diverging taper (percent)
50	4.3	7.2
60	3.6	6.0
70	3.1	5.2

### 5.3 Pedestrian Provision

To give pedestrians an extra measure of safety, solid pedestrian refuges should be located at points where pedestrians are generated, if the width of the flush median permits this (see below).

Refuges are especially necessary where pedestrian usage is high, and at pedestrian crossings. Where pedestrian usage is spread along the median refuges should be constructed approximately every 400 m.

Refuges should be installed at points of good visibility and where they can be well-lit (see Section 5.5). They also reinforce the prohibition on overtaking on flush medians, but as with any solid object in the carriageway can be a hazard to errant vehicles if not correctly delineated.

Pedestrian refuges are only recommended on urban (50 km/h) and semi-urban (70 km/h) roads.

The following detail shows a suitable pedestrian refuge. The recommended minimum width of the solid refuge is 1.8 m and the minimum length 8 m. The absolute minimum width of a solid refuge for this application is 1.2 m. A clearance of 300 mm between the median sideline and the solid refuge is recommended. Refer to NAASRA Part 5 "Intersections at Grade" 1988, Section 5.10.2, page 45 (10) and NAASRA Part 9 "Arterial Road Traffic Management" 1988, Section 3.2.3, page 15 (6) for further details.

Where pram crossings or gaps are installed through refuges they should turn pedestrians to face oncoming traffic.

Elderly pedestrians can make use of handrails on central refuge islands and their use has been effective in West Australia (11). Note however that the handrails themselves can be a hazard. Their use should be limited to areas where there is a real need for them.

PEDESTRIAN REFUGE DETAIL

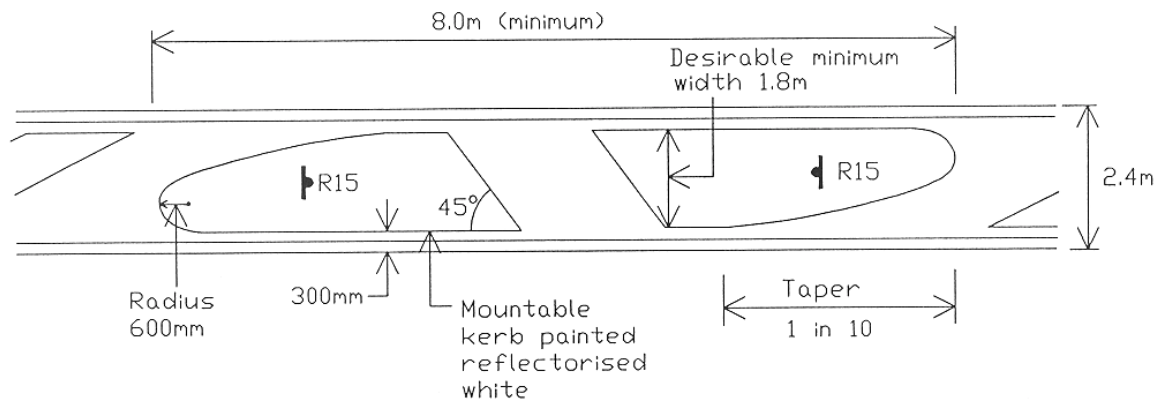

## 5.4 Intersection Treatments

The following recommended treatments are compatible with right turn pocket marking shown in the National Roads Board “Manual of Traffic Signs and Markings” 1975 (5), the National Roads Board “Guide to Urban Roadmarking” 1984 (4), and Transit New Zealand “RD 1 – Intersections at Grade” 1991 (12).

**NOTE:** The terms “moderate turning flows” and “low turning flows” can be related to the warrants for right turn pockets adopted by Transit New Zealand in “RD 1 Intersections at Grade” 1991 (4). That document adopts for urban and rural uses warrants contained in NAASRA Part 5 “Intersections at Grade” 1988 (10), Section 5.9.2, page 41. These warrants, it should be noted, are recommended for rural use in the Australian document, are interim and are under development. The basic warrant is 20 right turning vehicles in a peak hour, at an opposing flow rate of 300 or more vehicles per hour.

Right turn pocket development within a flush median is somewhat different from that of an isolated pocket as the right turning traffic is less exposed to collision from the rear, since vehicles are already waiting on the median. The decision to install a pocket may thus involve the consideration of other issues e.g. the status of the side road in the roading hierarchy.

The signposting of side roads in accordance with Ministry of Transport “Guidelines for Street Name Signs” (13) is recommended to help identify the location of side roads.

5.4.1.1 Simple "T" Intersection (moderate turning flows)

(See Note above.)

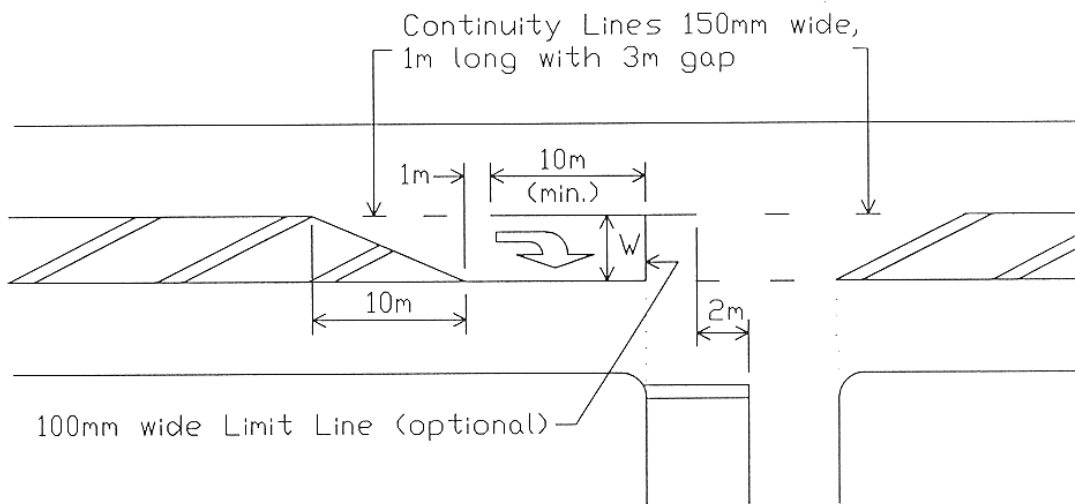

Note: W should not be less than 2.5m  
(minimum legal lane width)

5.4.1.2 Simple "T" Intersection (low turning flows)

(See Note above.)

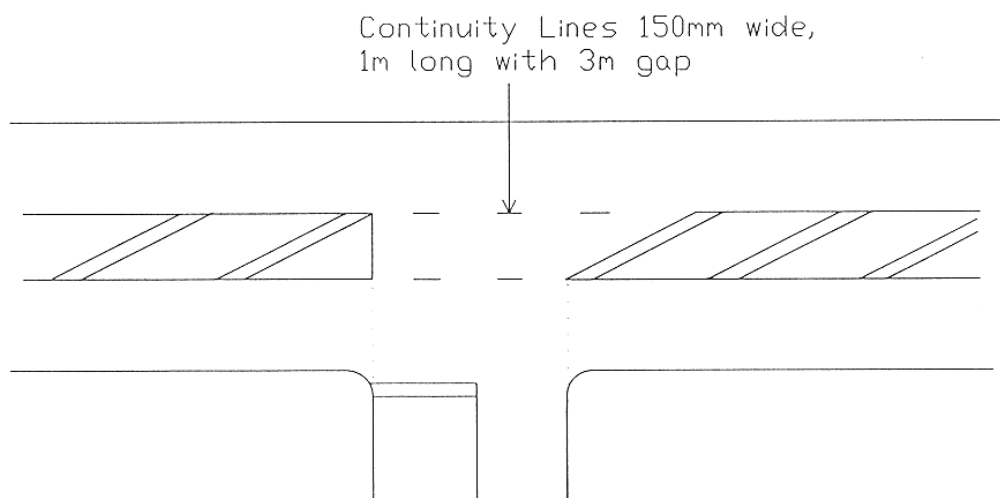

NOT TO SCALE

### 5.4.2.1 Simple Crossroad (moderate turning flows)

(See note above.)

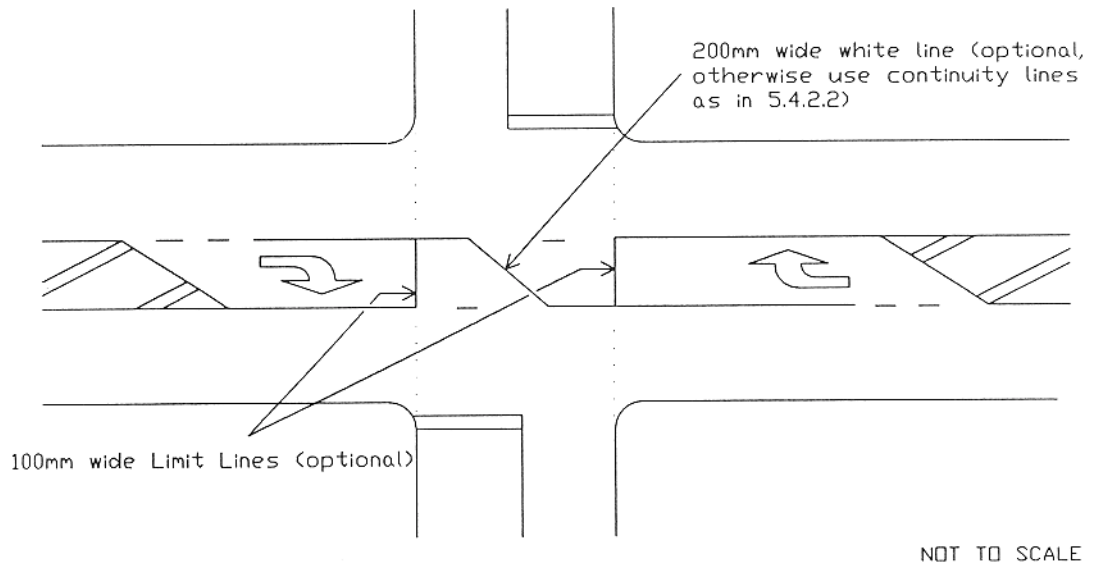

Other dimensions as per 5.4.1.1

### 5.4.2.2 Simple Crossroad (low turning flows)

(See note above.)

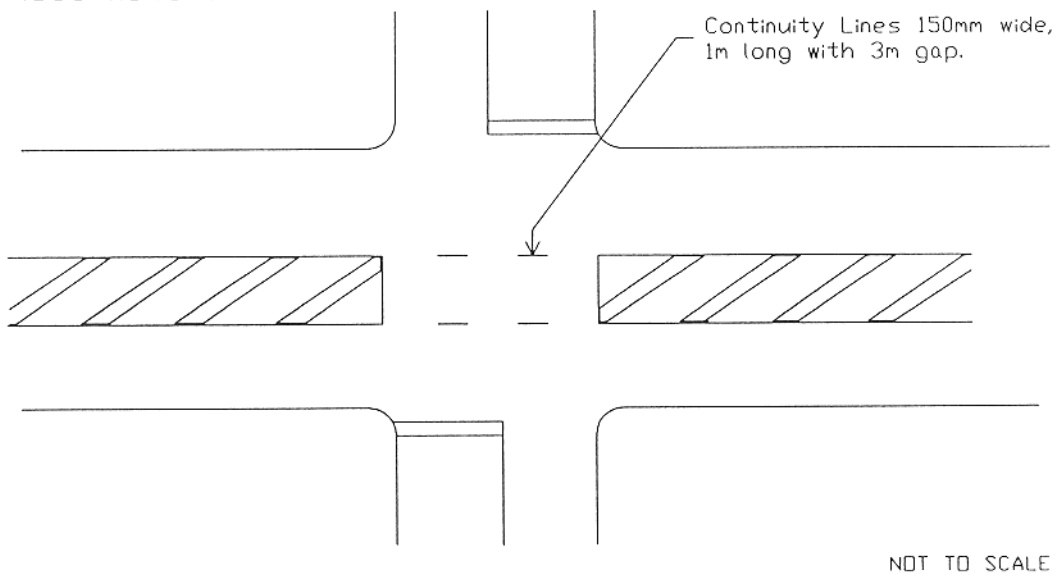

5.4.3.1 Offset "T" Intersection (moderate turning flows)

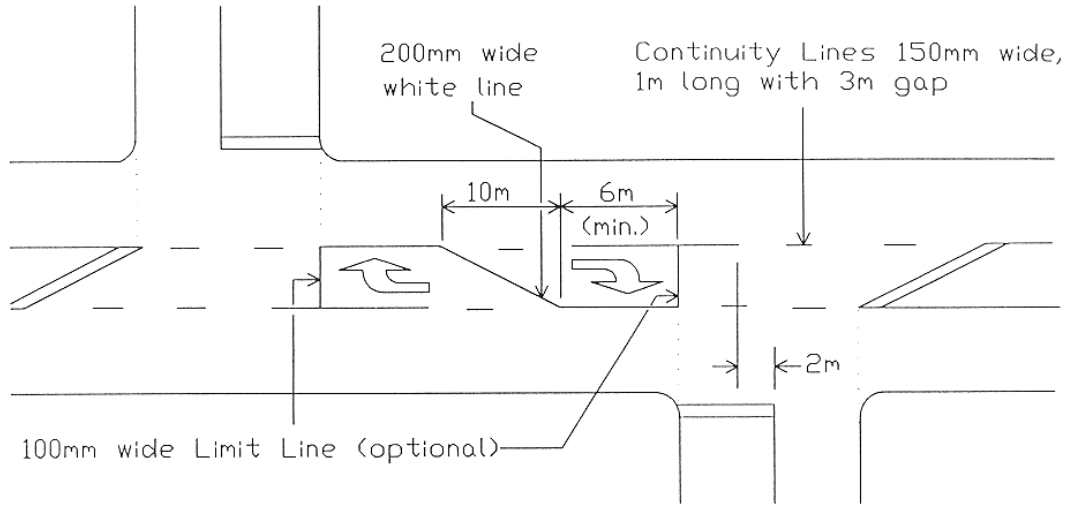

Other dimensions as per 5.4.1.1

5.4.3.2 Offset "T" Intersection (low turning flows)

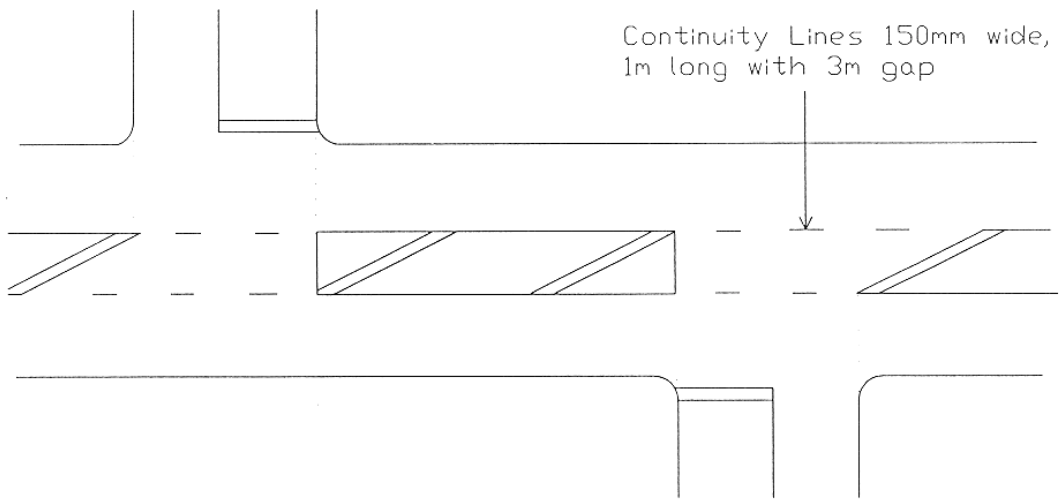

NOT TO SCALE

## 5.5 Night-time visibility and lighting

Flush medians need to be seen by drivers and pedestrians in adverse light or weather conditions or a combination of both. There are various ways of achieving this:

- (a) Appropriate street lighting (NZS 6701:1983 “Code of Practice for Road Lighting”) (14).
- (b) Use of thermoplastic material.
- (c) Use of raised reflective pavement markers (see next page).
- (d) Combinations of the above.

The recommended layout of raised reflective pavement markers is as follows:

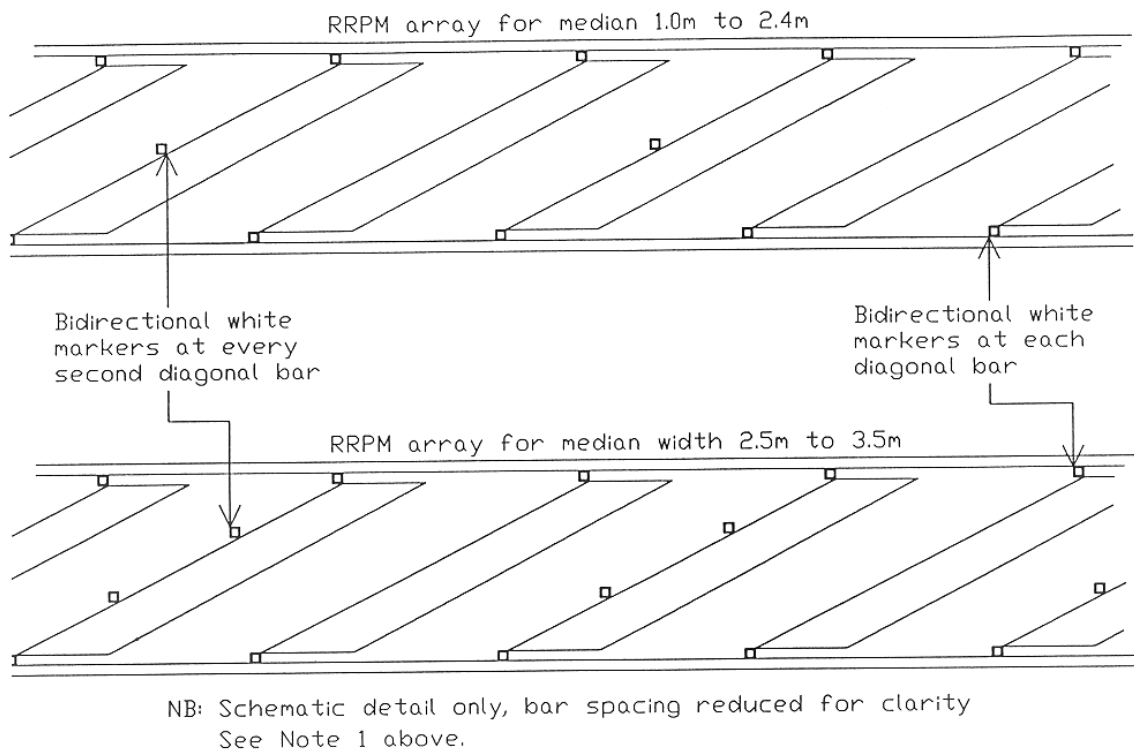

### Notes:

1. The minimum spacing of RRPMs is 10 metres. The minimum spacing of RRPMs on diagonal bars is thus 20 m. Where the bar spacing is less than 10 metres the RRPM array shown should be retained. However, the central RRPMs should be located on every third bar and the side line RRPMs located midway between each third bar. (see diagram p. 15)

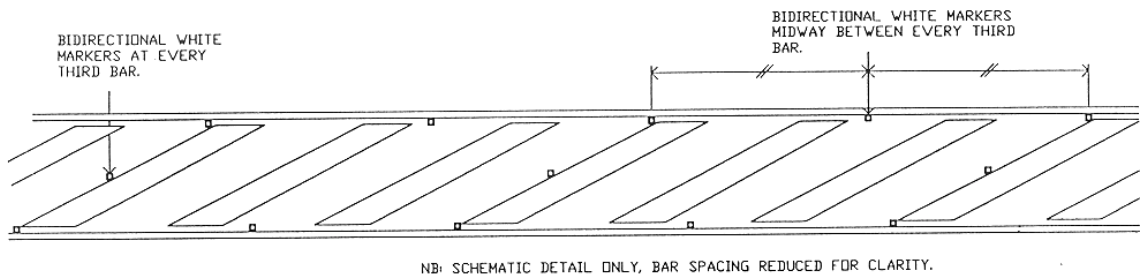

2. RRPMs should be laid at least 50 mm clear of adjacent paint or thermoplastic marking.

### Comment

A well lit smooth asphalt urban arterial road with a reflectorised white flush median would still suffer badly from glare on a wet night, and the use of RRPMs would be recommended.

A well lit urban arterial sealed with course chip seal with a thermoplastic flush median may well have adequate visual impact, even on a wet night.

Careful selection of the flush median material having regard for the lighting, road surface and road function is recommended.

When RRPMs are used it should be borne in mind that the maximum effective life has been measured as two years, and a regular inspection and replacement programme is recommended (15).

## 5.6 Colour and Materials

White is the only colour recommended for flush medians for the following reasons:

- (a) One of the compelling reasons for installing a flush median rather than a solid median is to enable its occasional use by turning vehicles. The use of colours other than white (for example, yellow) to impart different messages to motorists (for example, “keep off”) is subtle and unnecessary.
- (b) White and yellow markings can be indistinguishable under adverse light and weather conditions. Some evidence shows that yellow markings do not perform well under those conditions (16).
- (c) Both existing New Zealand references to flush medians recommend the use of white markings which have become the general expectation for motorists (5) (6).
- (d) Educating motorists to use flush medians only when turning right will be sufficiently resource intensive without the additional complication of different colours having different meanings.

The use of central “median lanes” marked with opposing right turn arrows is not recommended in New Zealand. Pedestrian protection is considered to be inadequate and night time delineation and identification difficult.

While reflected white paint is an accepted material for flush medians the use of white thermoplastic material is recommended as a potentially cost-beneficial alternative. Some of the advantages are:

- (a) Greatly enhanced life (with relatively low wear as flush medians are lightly trafficked).
- (b) Greater texture depth (which improves visual and tactile impact).
- (c) Better night-time visibility.
- (d) Higher skid resistance than paint.

## 6. References

1. United Kingdom County Surveyors Society Special Activity Group on Accident Reduction "*Carriageway Definition*" Report No. 1/8 June 1989.
2. Transit New Zealand "*Project Evaluation Manual*" 1991.
3. NAASRA "*Road Medians*" 1984.
4. National Roads Board "*Guide to Urban Road Marking*" 1984
5. National Roads Board "*Manual of Traffic Signs and Markings*" 1985.
6. NAASRA Part 9 "*Arterial Road Traffic Management*" 1988.
7. New Zealand Government "*Traffic Regulations*" 1976 (as amended).
8. Ministry of Transport "*Road Code*" 1991.
9. NAASRA Part 11 "*Parking*" 1988.
10. NAASRA Part 5 "*Intersections at Grade*" 1988.
11. Government of West Australia "*Safety for Seniors*" 1989.
12. Transit New Zealand "*RD 1 Intersections at Grade*" 1991.
13. Ministry of Transport "*Guidelines for Street Name Signs*" 1990.
14. Standards Association of New Zealand NZS 6701:1983 "*Code of Practice for Street Lighting*".
15. J. E Kemp "Effective lane delineation by retroreflective raised pavement markers" Proceedings 15th ARRB Conference (Part 5) 1990.
16. P.J. Moses "*Traffic Management and Safety in Europe and North America*" 1988.

## 7. Acknowledgements

This Guideline was prepared by Peter Kippenberger and Murray Noone, Road and Traffic Standards Section, Auckland, who gratefully acknowledge the assistance of:

**Steve Reddish**            Auckland City Council

**John Colyer**             Auckland City Council

**Brian Rainford**        Transit New Zealand

**Brian Zemanek**        Transit New Zealand

**Glenn Bunting**         Hamilton City Council

Members of the Transportation Group of the Institution of Professional Engineers of New Zealand.

## Road and Traffic Guideline publications

The following Road and Traffic Guidelines are available:

- RTS 1 Guidelines for the implementation of traffic control at crossroads (1990)
- RTS 2 Guidelines for street name signs (1990)
- RTS 3 Guidelines for establishing rural selling places (1992)
- RTS 4 Guidelines for flush medians (1991)
- RTS 5 Guidelines for rural road marking and delineation (1992)
- RTS 6 Guidelines for visibility at driveways (1993)
- RTS 7 Advertising signs and road safety: design and location guidelines (1993)
- RTS 8 Guidelines for safe kerblines protection (1993)
- RTS 9 Guidelines for the signing and layout of slip lanes (1994)
- RTS 11 Urban roadside barriers and alternative treatments (1995)
- RTS 13 Guidelines for service stations (1995)
- RTS 14 Guidelines for installing pedestrian facilities for people with visual impairment (1997)
- RTS 17 Guidelines for setting speed limits (1995)

The Guidelines may be purchased from:

Land Transport Safety Authority, Head Office (PO Box 2840, Wellington) or Regional Offices in:  
Auckland, (Private Bag 106 602), Wellington (PO Box 27 249) and Christchurch (PO Box 13 364).