

# Load restraint

10-1 Load anchorages

10-2 Stockcrates and stockcrate retention devices

10-3 Log bolsters

10-4 Headboards, sideboards and tailboards

10-5 Curtain systems



## Summary of legislation

### Applicable legislation

- Land Transport Rule: Heavy Vehicles 2004
- New Zealand Standard 5444: 1989 Load Anchorage Points for Heavy Vehicles
- New Zealand Standard 5444: 2005 Load Anchorage Points for Heavy Vehicles (applicable from 1/6/2005)

### Mandatory requirement

1. Load anchorage points (hooks, rope rails, twist locks, tie-down rings, keyhole plates and chain slots) must comply and be certified to NZS 5444.

### Mandatory equipment

2. A trailer that is constructed to transport a load must be fitted with load securing equipment (**Note 1**).
3. A trailer must have load anchorage points that are certified by a HVS certifier as complying with New Zealand Standard 5444, unless the trailer is one of the following:
  - a) a trailer fitted with a body that is specifically designed to contain the transported load without the use of lashings, chains or other devices, such as a tank body or a tipping body for transporting bulk goods (refer to section 3-1), or
  - b) a trailer fitted with a stockcrate and stockcrate retention devices (refer to section 10-2), or
  - c) a curtain-sided body fitted with a load-rated curtain and curtain anchorage system (refer to section 10-5), or
  - d) a trailer fitted with logging bolsters (refer to section 10-3).
4. A load anchorage must be certified by a HVS certifier of category HVIA, HVMA or HVEA.

### Condition

5. A certification label or plate must be:
  - a) clearly and indelibly marked, and
  - b) securely attached.
6. Load securing equipment that is fitted to a vehicle must be constructed to ensure that the load can be securely contained on the vehicle under all conditions of loading and operation for which the vehicle was constructed.

### Modification and repair

7. A modification or repair that affects a load anchorage point must be inspected and certified by a HVS certifier of category HVEA, HVMA or HVIA, unless the vehicle:
  - a) excluded from the requirement for HVS certification (**Table 10-1-2**), and
  - b) has been inspected in accordance with the requirements in this manual, including those for equipment, condition and performance.

## Reasons for rejection

### Mandatory requirements

1. A load anchorage point does not have evidence of certification to NZS 5444, ie:
  - a) the load anchorage point was fitted before the last CoF inspection, and after 1/1/1997, and no LANDATA record has been entered (Note: Before 1/1/1997 certification was required but for inspection purposes the LANDATA record need not be checked), or
  - b) the load anchorage point was fitted after the last CoF inspection and
    - i. a valid LT400 form has not been presented, or
    - ii. the HVS certifier was not of category HVEA, HVMA, HVIA, or
  - c) there is no valid certification label or plate attached to the vehicle (usually fitted to the left-hand chassis or coaming rail, or to the load platform) specified in **Table 10-1-1**.

### Mandatory equipment

2. A trailer constructed to transport a load is not fitted with load anchorage points (hooks, rope rails, twist locks, tie-down rings, keyhole plates or chain slots), unless the trailer is one of the following:
  - a trailer fitted with a body that is specifically designed to contain the transported load without the use of lashings, chains or other devices, such as a tank body or a tipping body for transporting bulk goods (refer to section 3-1)
  - a trailer fitted with a stockcrate and stockcrate retention devices (refer to section 10-2)
  - a curtain-sided body fitted with a load-rated curtain and curtain anchorage system (refer to section 10-5)
  - a trailer fitted with logging bolsters (refer to section 10-3).

### Condition

3. A certification label or plate:
  - a) is not indelibly marked, or
  - b) is illegible, or
  - c) is attached so that it is not easily visible, or
  - d) has details that do not match the vehicle, or
  - e) has obvious signs of tampering.

Reasons for rejection

- 4. A load anchorage component:
  - a) is missing, or
  - b) is not securely attached, or
  - c) is cracked or deformed, or
  - d) has significant corrosion damage, or
  - e) is worn beyond manufacturer's specifications.

Modification and repair

- 5. A modification or repair affects a load anchorage or its attachment and:
  - a) is not excluded from the requirements for HVS certification (Table 10-1-2), or
  - b) the modification is not for the purpose of law enforcement or the provision of emergency services, or
  - c) is missing proof of HVS certification, ie:
    - i. the vehicle was modified or repaired before the last CoF inspection and no LANDATA record has been entered, or
    - ii. the vehicle was modified or repaired since the last CoF inspection and no valid LT400 form from a HVS certifier of category HVEA, HVMA or HVIA has been presented.

Table 10-1-1. Minimum certification label and plate details required

NZS 5444: 1989	NZS 5444: 2005
Identity of the manufacturer Rated capacity of the load anchorage points	Certificate number HVS identifier Number and capacity of each type of load anchorage point fitted VIN or chassis number Any special conditions if applicable <b>Note: Any label or plate issued on or after 1/6/2005 must contain the above information</b>

**Table 10-1-2. Requirements for HVS certification**

HVS certification is required	HVS certification is not required
<p>1. Fitting of load anchorages</p>	<ol style="list-style-type: none"> <li>1. Repairs to coaming rails that do not support certified load anchorage points or J-hooks.</li> <li>2. A vehicle fitted with a bin lifting and hooking mechanism does not require HVS certification to NZS 5444, but the bin must be able to be secured safely using a fail-safe system. This may include a hydraulically operated and locked hook or similar, provided the locking device can only be opened by applying a positive and definitive hydraulic pressure.</li> <li>3. Tarpaulin hooks and load restraints fitted inside a box or van type body, eg to restrain furniture, are not considered to be load anchorages and therefore do not require HVS certification (it is recommended that tarpaulin hooks and rails are identified to be used only for retaining tarpaulins).</li> <li>4. Any modification or repair likely to have been carried out before 1/1/1997. (Modifications and repairs before this date generally required certification but for inspection purposes the LANDATA record need not be checked.)</li> <li>5. Any repair or modification not listed in the left-hand column unless the VI considers that certification is required because the modification or repair has affected the vehicle's safety performance (a second opinion from an expert may be needed, eg the manufacturer's representative, reputable workshop).</li> </ol>

**Note 1** Definition

**Load securing equipment** means equipment or a device permanently fitted to a vehicle to secure, either by itself or in conjunction with other equipment or devices such as lashings, a load to a vehicle.

## Summary of legislation

### Applicable legislation

- Land Transport Rule: Heavy Vehicles 2004
- New Zealand Standard 5413: 1993, Code of Practice for the Manufacture and Use of Stockcrates on Heavy Vehicles
- New Zealand Standard 5444: 1989, Load Anchorage Points for Heavy Vehicles
- New Zealand Standard 5444: 2005, Load Anchorage Points for Heavy Vehicles

### Mandatory equipment

1. A monocoque stock trailer with a GVM of 6000 kg or more, or a stockcrate and its retention devices, if fitted to a vehicle with a GVM of 6000 kg or more, must be constructed in accordance with NZS 5413.
2. Stockcrate anchorage points fitted to the deck of a vehicle must comply with and be certified to NZS 5444.
3. Stockcrate retention devices must be attached to the crate structure so as to transmit the restraint forces to the vehicle load platform or basic vehicle structure.

### Condition

4. External doors shall be firmly fixed to prevent stock from being ejected onto the roadway.
5. Load securing equipment must be constructed to ensure that the load can be safely contained on the vehicle under all conditions of loading and operation for which the vehicle was constructed.

### Modification and repair

6. A modification or repair that affects a stockcrate anchorage point must be inspected and certified by a HVS certifier of category HVEA, HVMA or HVIA, unless the vehicle:
  - a) excluded from the requirement for HVS certification (Table 10-2-2), and
  - b) has been inspected in accordance with the requirements in this manual, including those for equipment, condition and performance.

## Reasons for rejection

### Mandatory equipment

1. A monocoque stock trailer with a GVM of 6000 kg or more, or a stockcrate, including its retention devices (Figure 10-2-1), fitted to a vehicle with a GVM of 6000 kg or more, has no manufacturer's plate certifying construction in accordance with NZS 5413, that specifies at least all of the following details as appropriate:
  - company name
  - stockcrate serial number
  - date of manufacture of stockcrate
  - restraint capacity total in kg
  - restraint capacity individual in kg
  - number of restraints per side.
2. Stockcrate anchorage points fitted to the deck have not been certified to NZS 5444, ie:
  - a) the stockcrate anchorage points were fitted before the last CoF inspection, and after 1/1/1997, and there is no LANDATA record (Note: Before 1/1/1997 certification was required but for inspection purposes the LANDATA record need not be checked.), or
  - b) the stockcrate anchorage points were fitted after the last CoF inspection and:
    - i. a valid LT400 form is not presented, or
    - ii. the HVS certifier was not of category HVEA, HVIA or HVMA, or
    - iii. there is no valid certification plate/label attached to the vehicle as required in Table 10-2-1.

### Condition

3. A certification label or plate:
  - a) is not indelibly marked, or
  - b) is illegible, or
  - c) is attached so that it is not easily visible, or
  - d) has details that do not match the vehicle, or
  - e) has obvious signs of tampering.
4. The stockcrate's external doors:
  - a) are not securely attached to the stockcrate body, or
  - b) do not remain secure in a closed or locked position.

## Reasons for rejection

5. A J-hook assembly or other retention device, or an anchorage point:
  - a) is not securely attached, or
  - b) has a bush, fastener, washer, J-hook or other component missing or significantly corroded, or
  - c) is cracked or distorted, or
  - d) has cracks or corrosion damage on the stockcrate within 150 mm of the retention device attachment point, or
  - e) is not of a type suitable for retaining the stockcrate, or
  - f) is worn beyond manufacturer's specifications.

### Modification and repair

6. A modification or repair affects the stockcrate or its retention devices and:
  - a) is not excluded from the requirements for HVS certification (**Table 10-2-2**), or
  - b) the modification is not for the purpose of law enforcement or the provision of emergency services, or
  - c) is missing proof of HVS certification, ie:
    - i. the vehicle was modified or repaired before the last CoF inspection and no LANDATA record has been entered, or
    - ii. the vehicle was modified or repaired since the last CoF inspection and no valid LT400 form from a HVS certifier of category HVEA, HVMA or HVIA has been presented.

**Table 10-2-1. Minimum certification label and plate details required**

NZS 5444: 1989	NZS 5444: 2005
Identity of the manufacturer Rated capacity of the load anchorage points	Certificate number HVS identifier Number and capacity of each type of load anchorage point fitted VIN or chassis number Any special conditions if applicable <b>Note: Any label or plate issued on or after 1/6/2005 must contain the above information</b>

Table 10-2-2. Requirements for HVS certification

HVS certification is required	HVS certification is not required
1. Stockcrate retention devices that have been modified or repaired resulting in altered load ratings	<ol style="list-style-type: none"> <li>1. A stockcrate retention device has been repaired or modified, and the HVS certifier can confirm that the load ratings are still correct</li> <li>2. Any modification or repair likely to have been carried out before 1/1/1997. (Modifications and repairs before this date generally required certification but for inspection purposes the LANDATA record need not be checked.)</li> <li>3. Any repair or modification not listed in the left-hand column unless the VI considers that certification is required because the modification or repair has affected the vehicle's safety performance (a second opinion from an expert may be needed, eg the manufacturer's representative, reputable workshop).</li> </ol>

**Note 1** Definitions

**Body** means the part of the vehicle that is designed for the use and accommodation of the occupants or to hold any goods. It comprises the load platform/deck, headboard, sideboards, tailgate, coaming rails, cross members, runners and attachment to the chassis.

**Chassis** means the structural lower part of a vehicle to which the running gear and, as applicable, engine, transmission, steering system and body may be attached.

**J-hook** means a retention device fabricated from metal for the retention of stackcrates to the vehicle load platform, mounted in such a way as to be fixed either inside or outside the coaming rail vertically and tensioned through a bush on the crate structure by way of a threaded fastener.

**Load anchorage point** means a device permanently attached to a vehicle to enable a load to be secured or attached to the vehicle.

**Monocoque** in relation to a vehicle, means that the chassis of the vehicle is integral to the body.

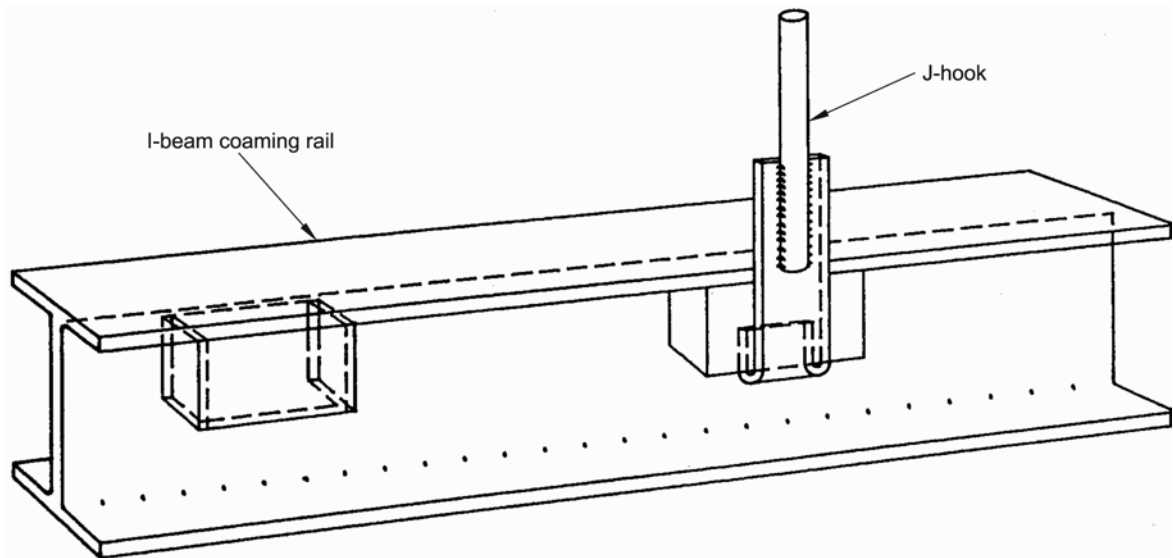
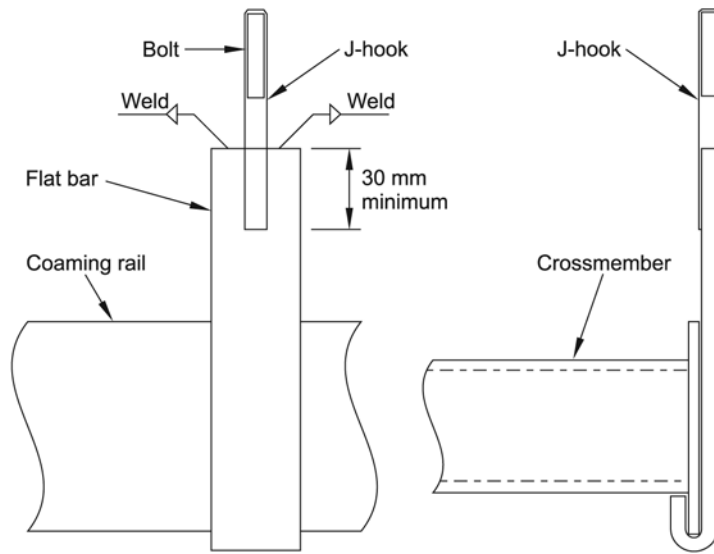

Figure 10-2-1: Types of acceptable J-hooks

## Summary of legislation

### Applicable legislation

- Land Transport Rule: Heavy Vehicles 2004
- Bolster Attachment Code (issue 27 November 1998)
- Bolster Attachment Code (issue 1 May 2001)
- NZ Gazette 14/1/1999, issue 1, page 64
- NZ Gazette 27/5/1999, issue 60, page 1431
- NZ Gazette 26/4/2001, issue 43, page 957

### Mandatory requirement

1. A logging bolster attachment fitted to a vehicle must comply with the requirements in **Table 10-3-1**.
2. Certification of a logging bolster attachment must be certified by a HVS certifier of category HVIL, HVML or HVEL.

### Mandatory equipment

#### Bolster Attachment Code (issue 27/11/1998)

3. Individual bolsters must be stamped, indelibly labelled or marked to clearly identify:
  - a) the bolster manufacturer, and
  - b) bolster serial number, and
  - c) rated bolster load.
4. The vehicle must be fitted, on the LHS chassis rail as far as practical in line with the front of the coaming rail, with at least one tag identifying:
  - a) the bolsters, and
  - b) the bolster attachment, and
  - c) the vehicle, and
  - d) the expiry date.

#### Bolster Attachment Code (issue 1/5/2001)

5. Individual bolsters must be stamped, indelibly labelled or marked to clearly identify their serial number.
6. Individual bolster mounts must be stamped, indelibly labelled or marked to clearly identify their serial number.
7. The vehicle must be fitted with at least one tag identifying the bolsters, bolster attachments, bolster rating, the HVS certifier, the bolster manufacturer, the vehicle and the expiry date.

### Condition

8. Load securing equipment that is fitted to a vehicle must be constructed to ensure that the load can be securely contained on the vehicle under all conditions of loading and operation for which the vehicle was constructed.
9. A load-bearing structure must be of adequate strength for all conditions and loading for which the vehicle was constructed.

## Reasons for rejection

### Mandatory requirement

1. A logging bolster attachment fitted to a vehicle that is required to be certified in **Table 10-3-1** does not have evidence of certification.
2. A logging bolster attachment fitted to a vehicle certified to the Bolster Attachment Code (issue 1/5/2001) does not have evidence of certification, ie:
  - a) the attachment was fitted before the last CoF inspection and there is no LANDATA record of the certification, or
  - b) the attachment was fitted after the last CoF inspection and:
    - i. a valid LT400 form is not presented, or
    - ii. the HVS certifier was not of category HVEL, HVIL or HVML.
  - c) individual bolsters are not stamped, indelibly labelled or marked to clearly identify their serial numbers, or
  - d) individual bolster attachments are not stamped, indelibly labelled or marked to clearly identify their serial numbers, or
  - e) the vehicle is not fitted on the left hand chassis rail with at least one tag clearly identifying the bolsters, bolster attachments, bolster rating, the HVS certifier, the bolster manufacturer, the vehicle and the expiry date.
3. A logging bolster attachment fitted to a vehicle certified to the Bolster Attachment Code (issue 27/11/1998) does not have evidence of certification, ie:
  - a) there is no LANDATA record of the certification, or
  - b) individual bolsters are not stamped, indelibly labelled or marked to clearly identify the bolster manufacturer, the bolster serial number and the rated bolster load, or
  - c) the vehicle is not fitted on the left hand chassis rail with at least one tag to clearly identify the bolsters, bolster attachment, the vehicle and the expiry date.
4. A logging bolster attachment on a long log logging vehicle fitted with a convertible (sliding or folding) bolster does not have evidence of certification required in **Table 10-3-1**, ie there is no LANDATA record of the certification.

### Modification and repair

10. A modification or repair that affects a log bolster attachment must be inspected and certified by a HVS certifier of category HVEL, HVML or HVIL, unless the vehicle:
- excluded from the requirement for HVS certification (**Table 10-3-2**), and
  - has been inspected in accordance with the requirements in this manual, including those for equipment, condition and performance.

### Reasons for rejection

#### Condition

- A required certification label, plate, or marking is:
  - illegible, or
  - incorrect, eg serial numbers differ between the label and the bolsters, or
  - expired.
- A log bolster or log bolster mounting, including a component such as a load cell, weld and fastener:
  - is missing, or
  - is not securely attached, or
  - is cracked or deformed, or
  - has significant corrosion damage, or
  - is worn beyond manufacturer's specifications, or
  - has excessive wear between mating surfaces.
- A sliding bolster locking device:
  - is missing, or
  - is not effective, or
  - is of an unacceptable type, eg. air or hydraulic slide cylinder or chain drives.

#### Modification and repair

- A modification or repair affects the log bolster or its attachment and:
  - is not excluded from the requirements for HVS certification (**Table 10-3-2**), or
  - the modification is not for the purpose of law enforcement or the provision of emergency services, or
  - is missing proof of HVS certification, ie:
    - the vehicle was modified or repaired before the last CoF inspection and no LANDATA record has been entered, or
    - the vehicle was modified or repaired since the last CoF inspection and no valid LT400 form from a HVS certifier of category HVEL, HVML or HVIL has been presented.

Table 10-3-1. Logging bolster attachment certification requirements

Fitted before 1/10/1999	Fitted 1/10/1999–30/4/2001	Fitted from 1/5/2001
No certification	<p>Either</p> <p>Bolster Attachment Code (issue 27/11/1998)</p> <p>or</p> <p>Bolster Attachment Code (issue 1/5/2001)</p> <p>or,</p> <p>optional for convertible bolsters on long log logging vehicles until 31/3/2005:</p> <ul style="list-style-type: none"> <li>certification that the same design of bolster attachments has successfully completed 250,000 km of service on a single vehicle without indications of fatigue or failure.</li> </ul>	<p>All bolster attachments:</p> <p>Bolster Attachment Code (issue 1/5/2001)</p> <p>or,</p> <p>optional for convertible bolsters on long log logging vehicles until 31/3/2005:</p> <ul style="list-style-type: none"> <li>certification that the same design of bolster attachments has successfully completed 250,000 km of service on a single vehicle without indications of fatigue or failure.</li> </ul>

Table 10-3-2. Requirements for HVS certification

HVS certification is required	HVS certification is not required
<p>1. Any repairs to the bolster attachments</p>	<p>1. Where a fastener fails the inspection, the CoF inspector must request a written report from a HVS certifier of category HVEL, HVML or HVIL who will disassemble the fasteners and confirm that:</p> <ol style="list-style-type: none"> <li>Movable parts such as lock pins have been checked for proper operation and engagement, and</li> <li>Mating parts seat correctly, and</li> <li>Fasteners have been fitted to manufacturer's specifications and bolt torques are correct, and</li> <li>Any other manufacturer's requirements have been complied with.</li> </ol> <p>2. Any modification or repair likely to have been carried out before 1/1/1997. (Modifications and repairs before this date generally required certification but for inspection purposes no evidence of this is required.)</p> <p>3. Any repair or modification not listed in the left-hand column unless the VI considers that certification is required because the modification or repair has affected the vehicle's safety performance (a second opinion from an expert may be needed, eg the manufacturer's representative, reputable workshop).</p>

**Note 1** A convertible bolster is usually slid to a different position or dropped down to allow long logs to span two trailers.

**Note 2** Definition

**Logging bolster** means a vertically orientated member attached to a vehicle that is used to secure loads of timber logs.

## Summary of legislation

### Applicable Legislation

- Land Transport Rule: Heavy Vehicles 2004

### Condition

1. A headboard, sideboard or tailboard fitted to a vehicle for the purpose of restraining a load on that vehicle must be of adequate strength to withstand load forces without incurring permanent deformation.
2. A headboard, sideboard or tailboard in must be fitted to a vehicle in a way that ensures that the parts of the vehicle to which it is attached are able to withstand the forces exerted by the headboard, sideboard or tailboard without incurring permanent deformation.

## Reasons for rejection

### Condition

1. A headboard, sideboard or tailboard:
  - a) is not securely attached, or
  - b) has a fastener that is missing or loose, or significantly corroded, or
  - c) is cracked or significantly distorted or corroded.

### Note 1 Definitions

**Headboard** means the substantially vertical part of the forward end of a flat deck or curtain-sided body of a vehicle.

**Sideboard** means the substantially vertical part of the side of a flat deck body of a vehicle.

**Tailboard** means the substantially vertical part of the rear end of a flat deck or curtain-sided body of a vehicle.

## Summary of legislation

### Applicable legislation

- Land Transport Rule: Heavy Vehicles 2004

### Mandatory equipment

1. If a vehicle has a curtain-sided body that is constructed to secure a load on a vehicle, each curtain and curtain anchorage system must:
  - a) have a manufacturer's load rating appropriate for all conditions of loading and operation of the vehicle; and
  - b) be clearly marked with the manufacturer's load rating in kilograms per metre, in a position on the curtain that is readily accessible for inspection purposes.

### Condition

2. Load securing equipment that is fitted to a vehicle must be constructed to ensure that the load can be securely contained on the vehicle under all conditions of loading and operation for which the vehicle was constructed.

## Reasons for rejection

### Condition

1. A load-rated curtain (**Notes 1 and 2**):
  - a) is ripped, or
  - b) has deteriorated resulting in weakening of the curtain material, eg crazing, brittleness, stiffness, or
  - c) has become detached from the frame, or
  - d) has been poorly repaired.
2. A load-rated curtain tensioning system component:
  - a) is missing, or
  - b) is not securely attached, or
  - c) is damaged, cracked or deformed, or
  - d) has significant corrosion damage, or
  - e) is worn beyond manufacturer's specifications, or
  - f) does not function correctly.
3. A non-load-rated curtain is deteriorated such that parts could come loose (**Note 3**).

**Note 1** For the purposes of this inspection, a load-rated curtain is one that has labelling that includes the manufacturer's load rating in kilograms per metre.

**Note 2** Advice from the curtain manufacturer may be required in case of doubt about damage and deterioration limits and quality of repairs.

**Note 3** For curtain siders that are not load rated, refer to section 10-1 Load anchorages for requirements.